

**SPEC:**

**A. Material:**

1. Housing: PA66

2. Terminal: COPPER ALLOY, TIN PLATED

**B. Electrical Characteristics:**

1. Rating: 10A 250V~

2. Electric Strength: AC 2,000 V FOR ONE MINUTE

3. Insulation Resistance: 100MΩ MIN, AT 500V DC

**C. Approvals:**

UL, CUL, CCC, ENEC

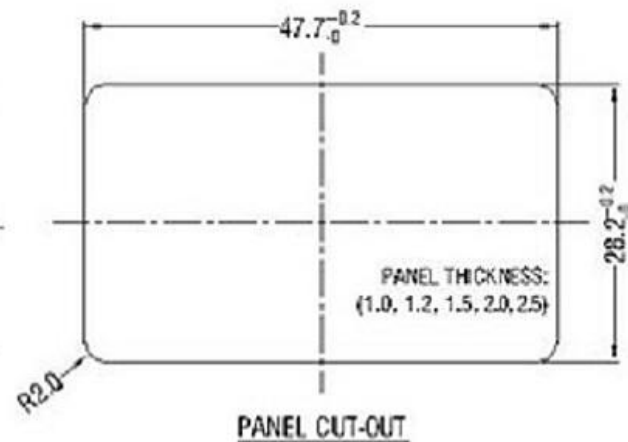
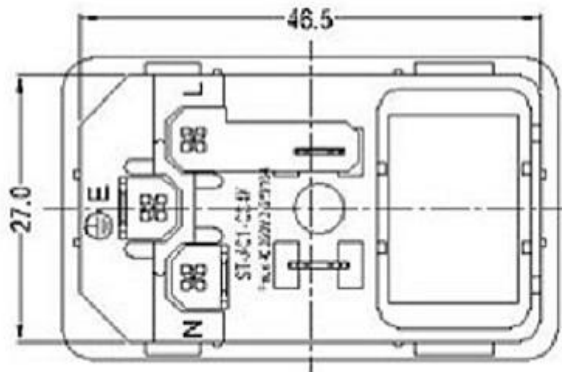
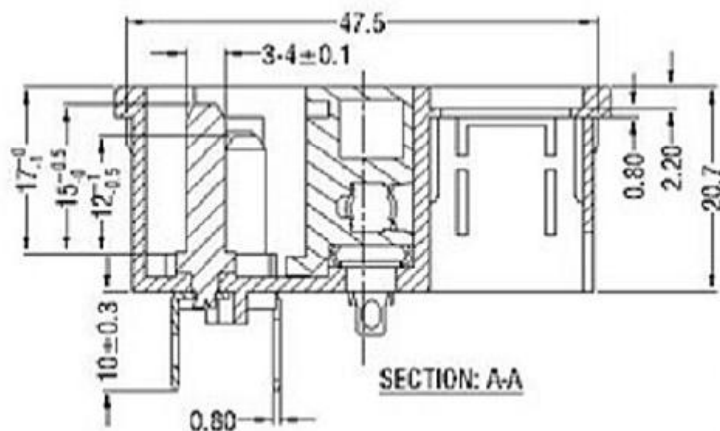

Part No.:	DIM. X
ST-A01-004K-JY-010-D	1.0
ST-A01-004K-JY-012-D	1.2
ST-A01-004K-JY-015-D	1.5
ST-A01-004K-JY-020-D	2.0
ST-A01-004K-JY-025-D	2.5

普通公差

COMMON TOLERANCE :

UP TO 5	±0.20
ABOVE 5 TO 30	±0.30
ABOVE 30	±0.50
ANGULAR	±5°



东莞市高迪电子有限公司

REV.	DATE	REVISION DESCRIPTION	ISSUE	单位 UNIT	mm	投影 PROJECTED	品名 PRODUCT NAME	AC POWER JACK
				绘图 DRAWN BY	林晓良	核对 CHECKED BY	型号 MODEL NO.	
				日期 DATE	19. 08. 12	核准 APPROVAL BY	料号 PART NO.	KD-AC电源插座